

wilko

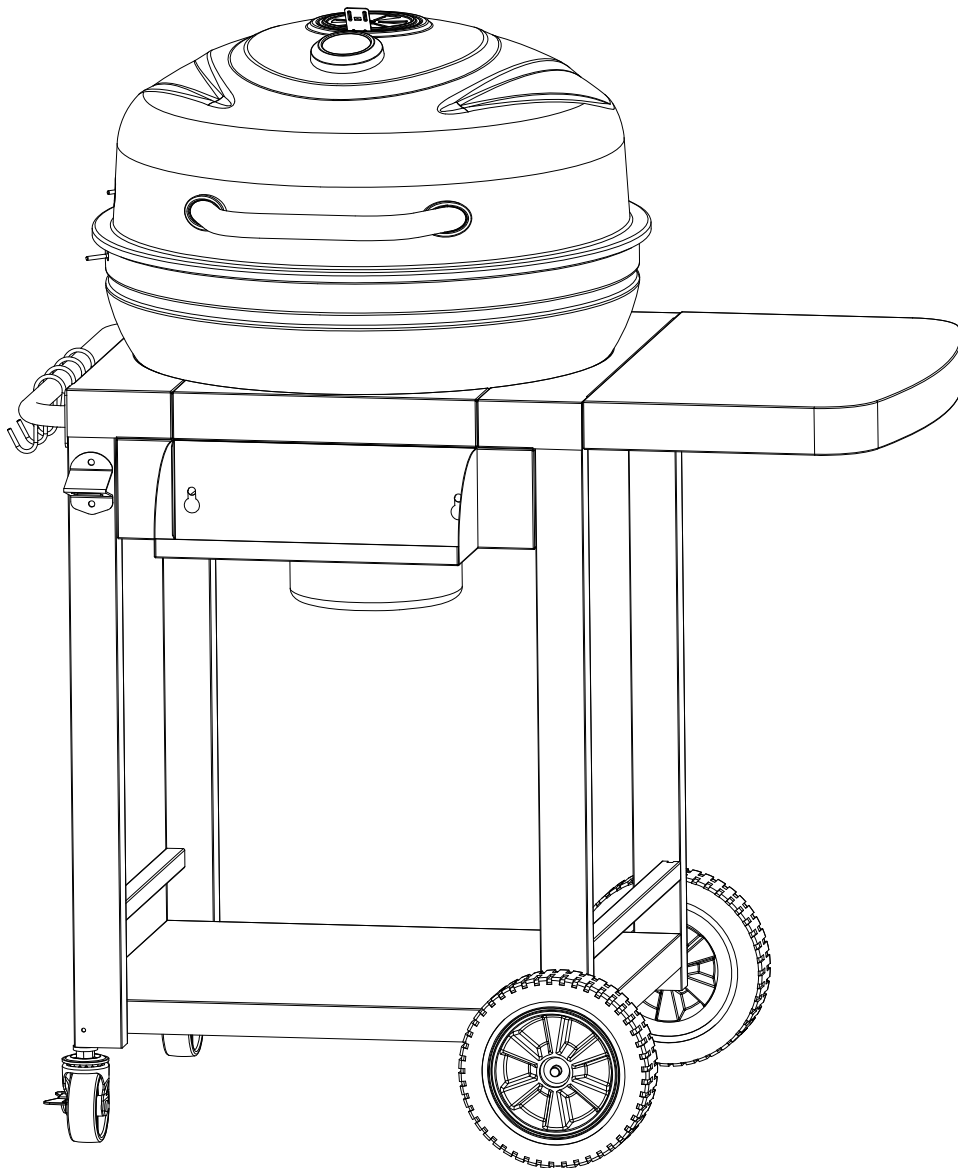

KETTLE CHARCOAL GRILL

Assembly instruction (0464172)



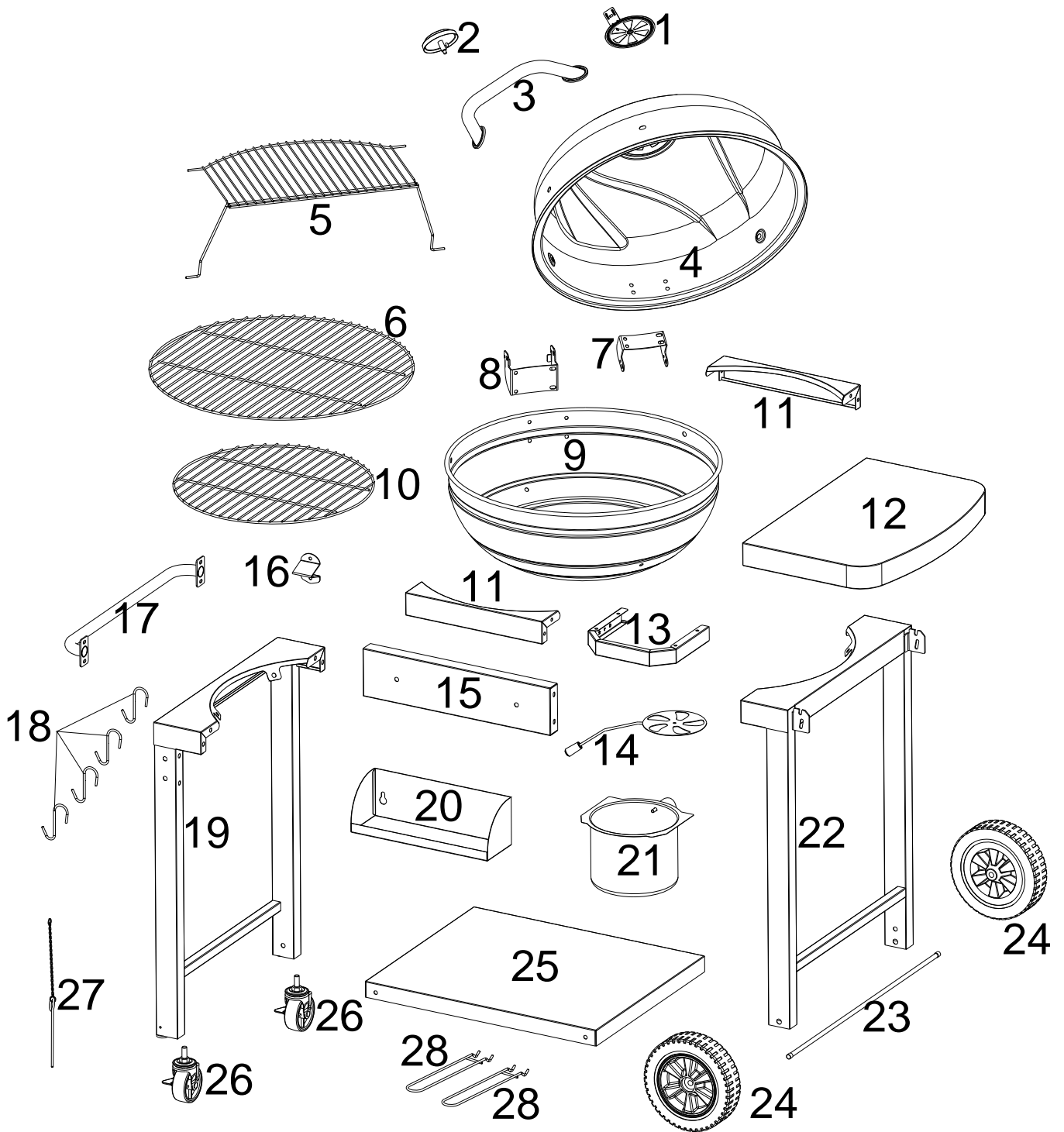

















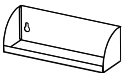



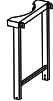

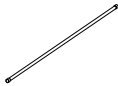
Expanded View



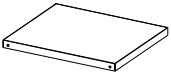
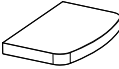

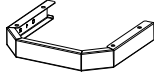





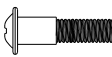

Parts Supplied

Please check parts against the list below before assembling your Barbecue Grill.

Take a few moments to familiarise yourself with the contents. Check that all holes are clear of paint before assembly, if you find a blockage, please use a screw driver to clear the blocked hole.

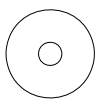
1	Air vent		1	15	Cart front panel		1
2	Temperature gauge		1	16	Bottle opener		1
3	Lid handle		1	17	Cart handle		1
4	Lid		1	18	Hook		4
5	Warming rack		1	19	Left cart frame		1
6	Cooking grid		1	20	Condiment tray		1
7	Top hinge		1	21	Ash receiver		1
8	Bottom hinge		1	22	Right cart frame		1
9	Firebowl		1	23	Axle		1
10	Charcoal grid		1	24	Wheel		2
11	Cart frame support		2	25	Bottom panel		1
12	Side shelf		1	26	Locking caster		2
13	Ash receiver slide		1	27	Pin		1
14	Firebowl air vent		1	28	Cooking grid handle		2

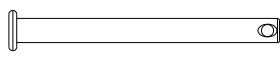
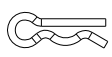
Fittings Supplied

A	Screw M4x10		6
B	Screw M5x18		4
C	Screw M6x14		38
D	Wing nut M4		2
E	Wing nut M6		8
F	Nut M10		2
G	Washer \varnothing 6		12
H	Washer \varnothing 22		2
I	Lock Washer \varnothing 6		14
J	Pin \varnothing 8x110mm		1
k	Cotter Pin \varnothing 1.4x30mm		1
L	Wrench M10		2

Screwdriver (not included) and wrench (included) are required to assemble the Barbecue.

- . Dispose of all polythene packing carefully and keep out of the reach of children
- . Please read the section on barbecue safety prior to using your Barbecue.
- . Two people are recommended for assembly.

Please read all instructions carefully and keep outer packaging to refer to photograph of finished product in case of difficulty.

Assembly

Please read all instructions thoroughly before proceeding. Find a large, clean area in which to assemble your barbecue. Please refer to parts list and assembly diagram as necessary. Assembly of the barbecue involves many large components, it is advisable to have two people assemble the unit.

STEP 1:

A: Attach cart frame support (11) to left cart frame (19) ((C) Screw 4Pcs).

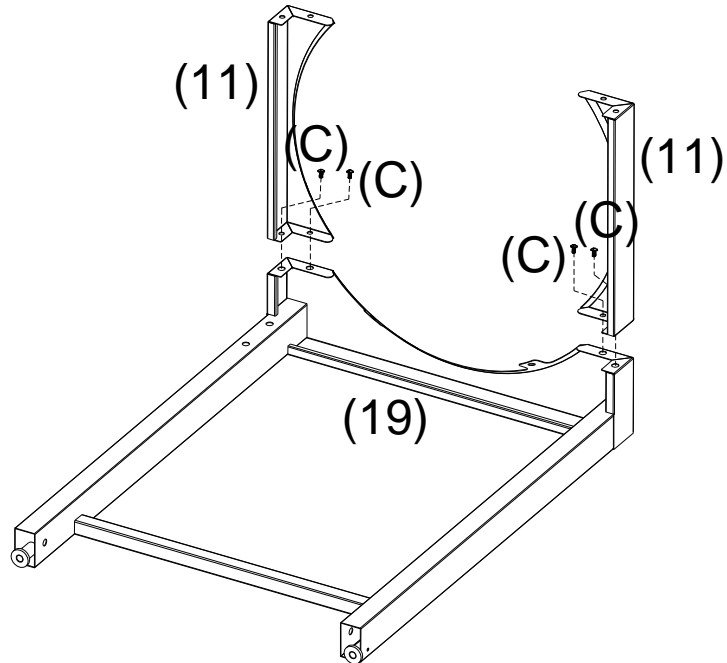

STEP 2:

A: Attach right cart frame (22) to cart frame supports ((C) Screw 4Pcs).

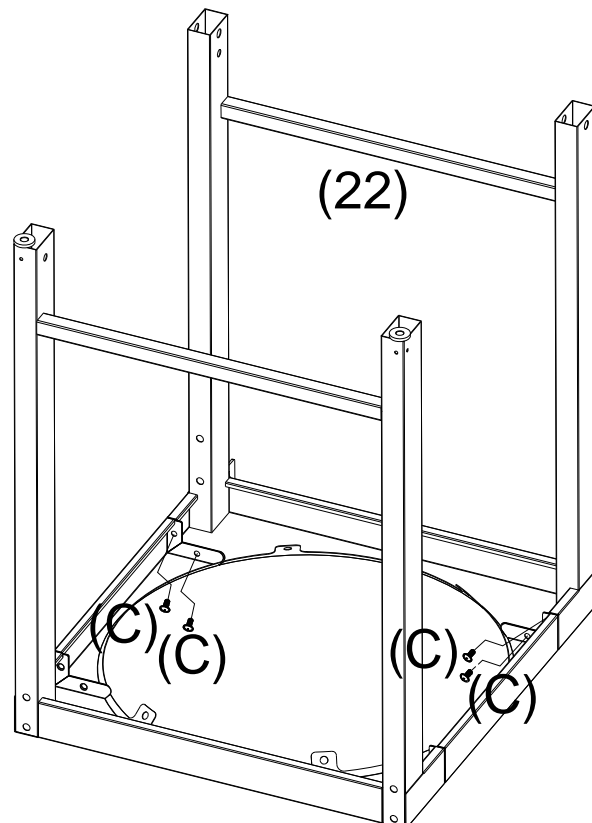

STEP 3:

A: Attach cart front panel (15) to left cart frame and right cart frame ((C) Screw 4Pcs).

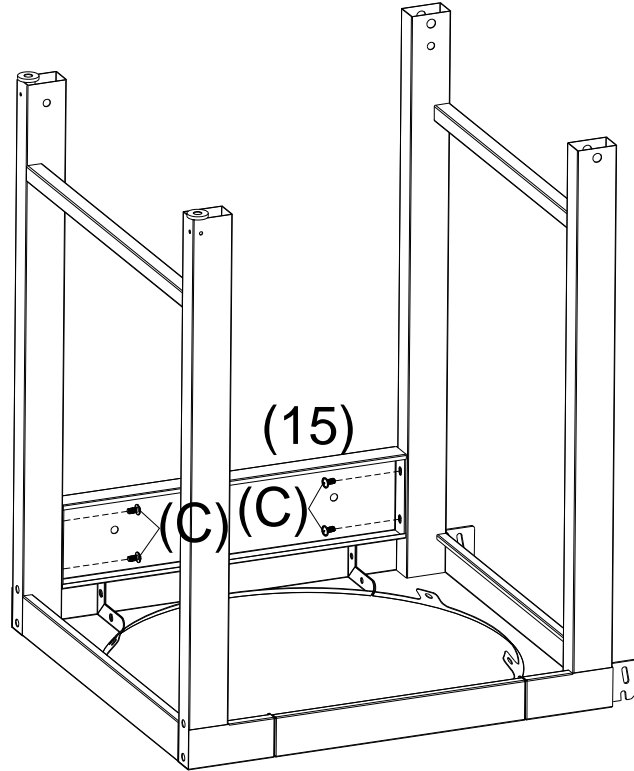

STEP 4:

A: Attach bottom panel (25) to left cart frame and right cart frame ((C) Screw 4Pcs).

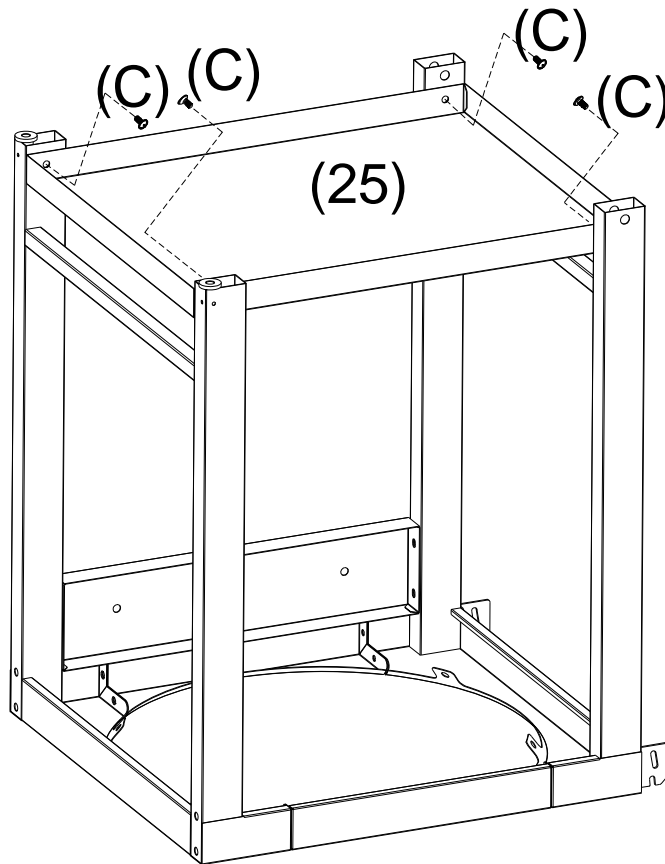

STEP 5:

A: Attach axle (23), wheels (24) to right cart frame ((F) Nut 2Pcs).

B: Insert locking caster (26) into hole of left cart frame.

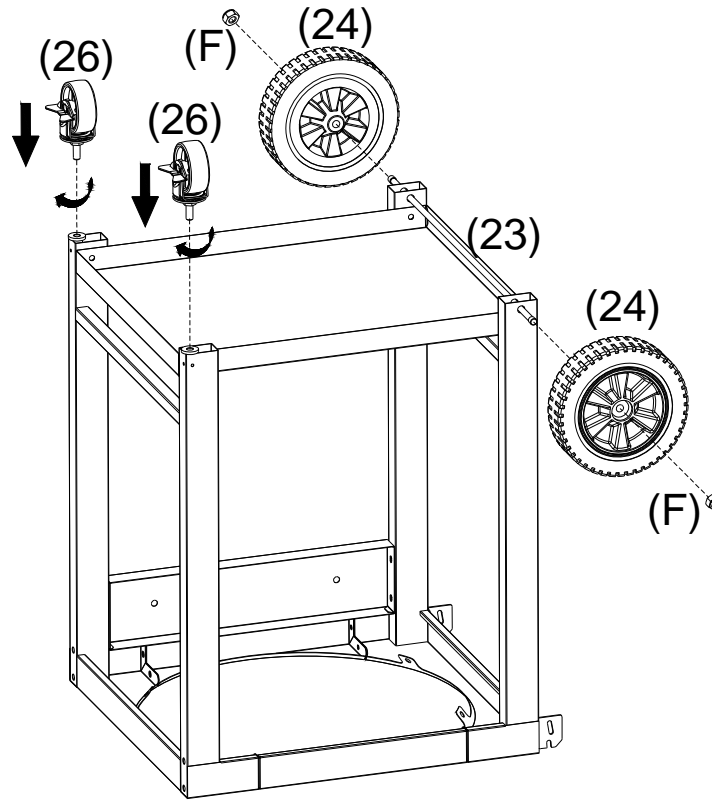

STEP 6:

A: Attach cart handle (17) to left cart frame ((C) Screw 4Pcs).

B: Attach bottle opener (16) to left cart frame ((C) Nut 2Pcs).

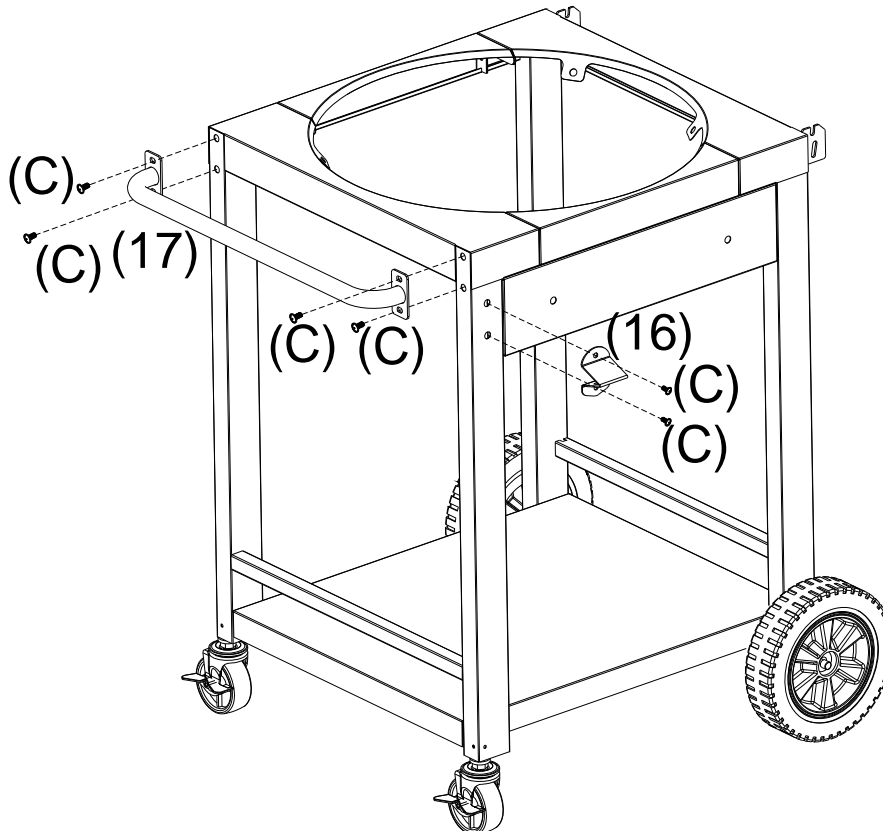

STEP 7:

A: Attach condiment tray (20) to front panel ((C) Screw 2Pcs).

Note: Pre-assemble 2 screws to front panel, leave 5mm exposed.

B: Hang the hooks (18) onto cart handle.

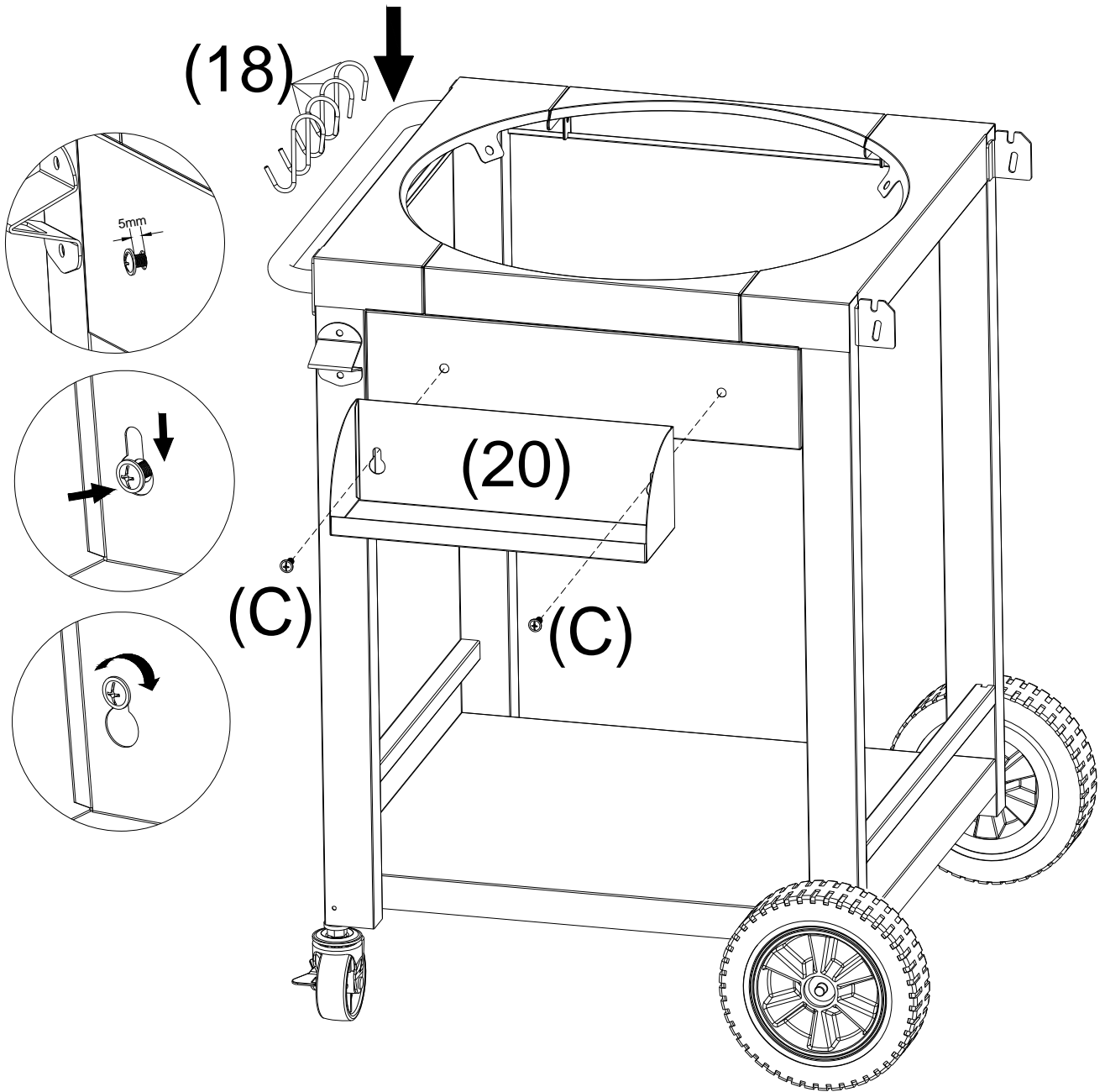

STEP 8:

A: Attach side shelf (12) onto right cart frame ((B) Screw 4Pcs).

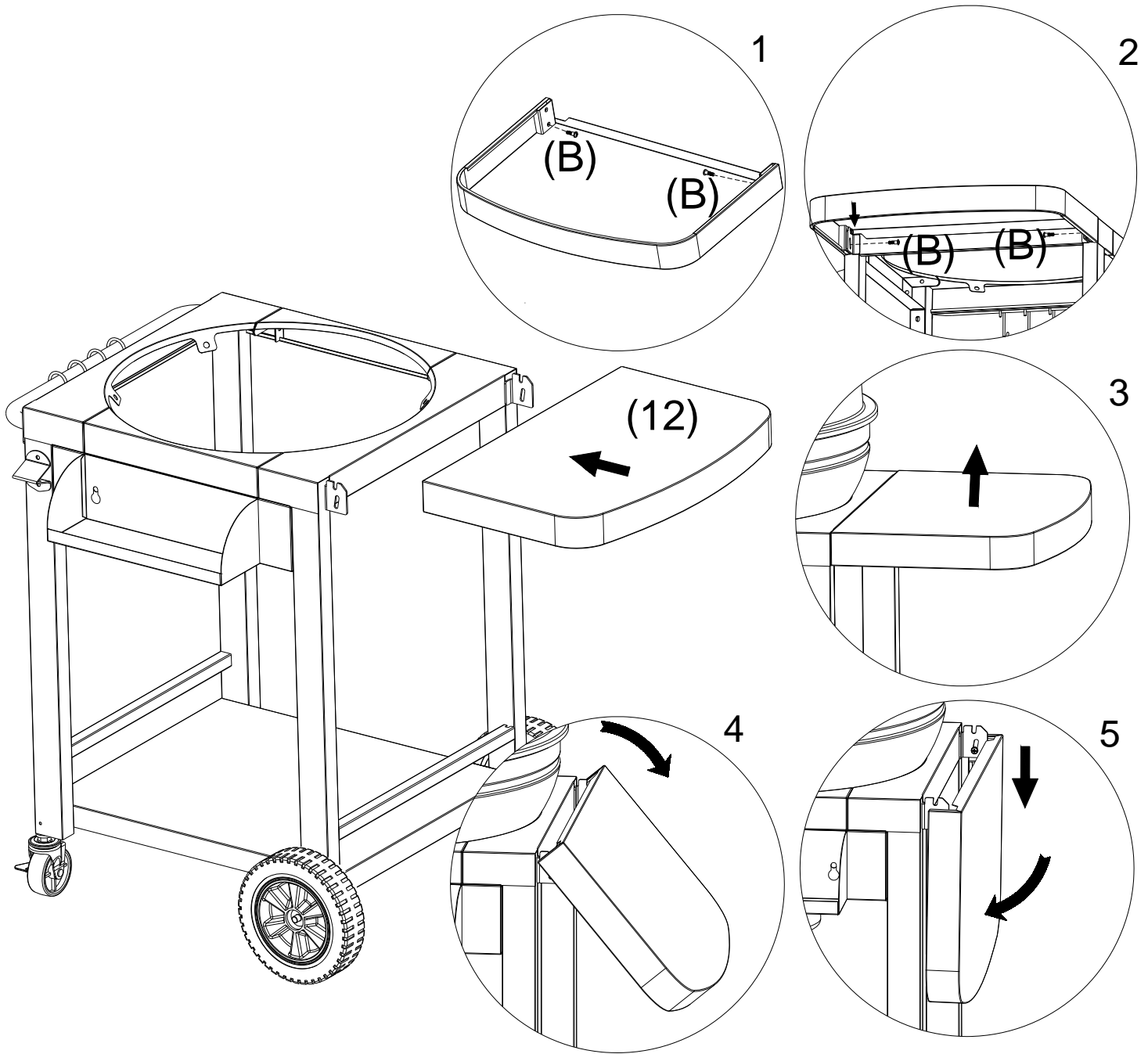

STEP 9:

A: Attach firebowl (9) to cart frames ((C) Screw 4Pcs / (I) Lock washer 4Pcs / (G) Washer 4Pcs).

B: Attach bottom hinge (8) to firebowl (9) ((C) Screw 4Pcs / (G) Washer 4Pcs / (I) Lock Washer 4Pcs / (E) Wing nut 4Pcs).

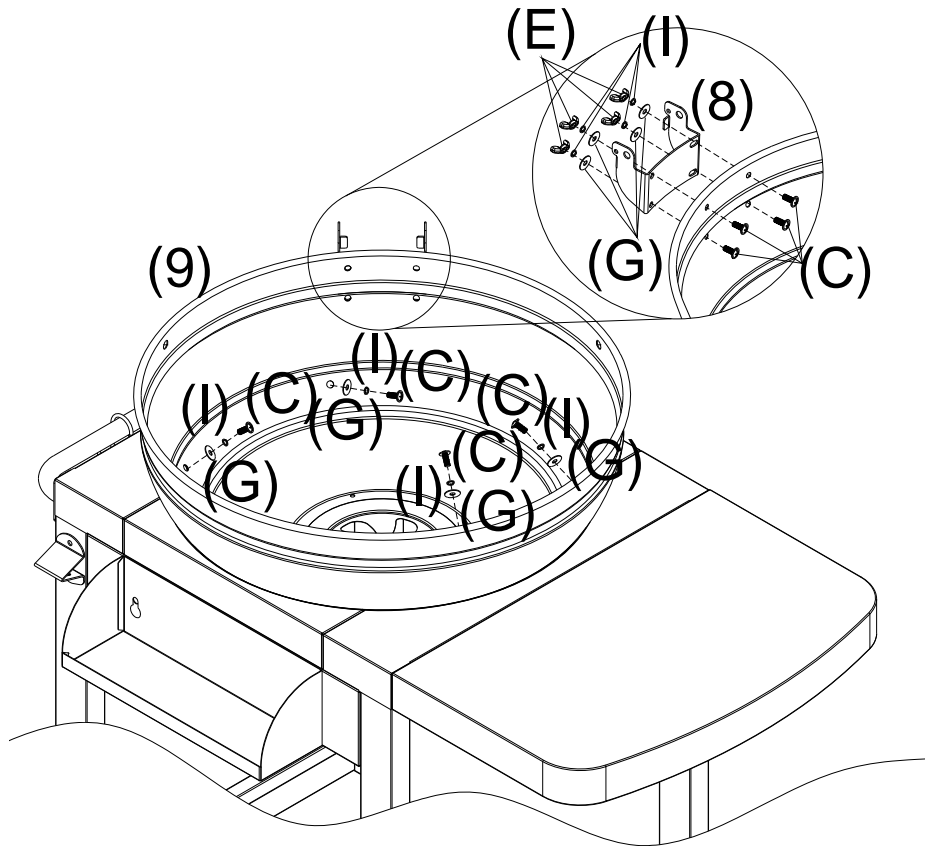

STEP 10:

A: Attach ash receiver slide (13) to firebowl ((A) Screw 4Pcs).

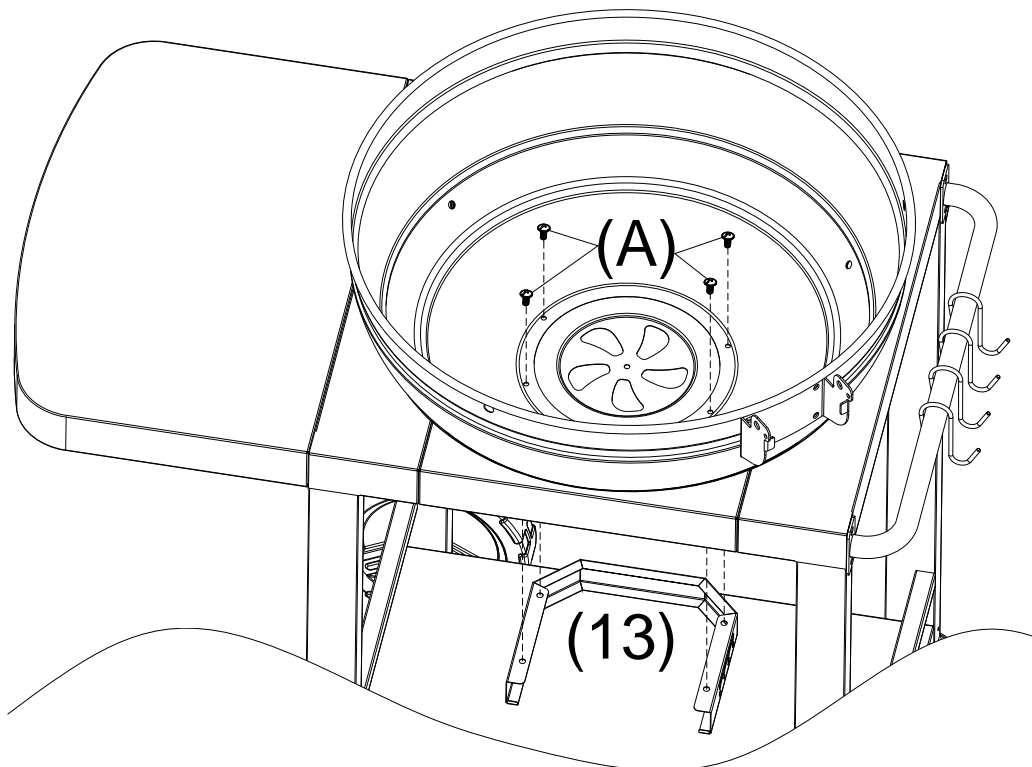

STEP 11:

A: Attach firebowl air vent (14) to firebowl ((A) Screw 1Pc / (D) Wing nut 1Pc).

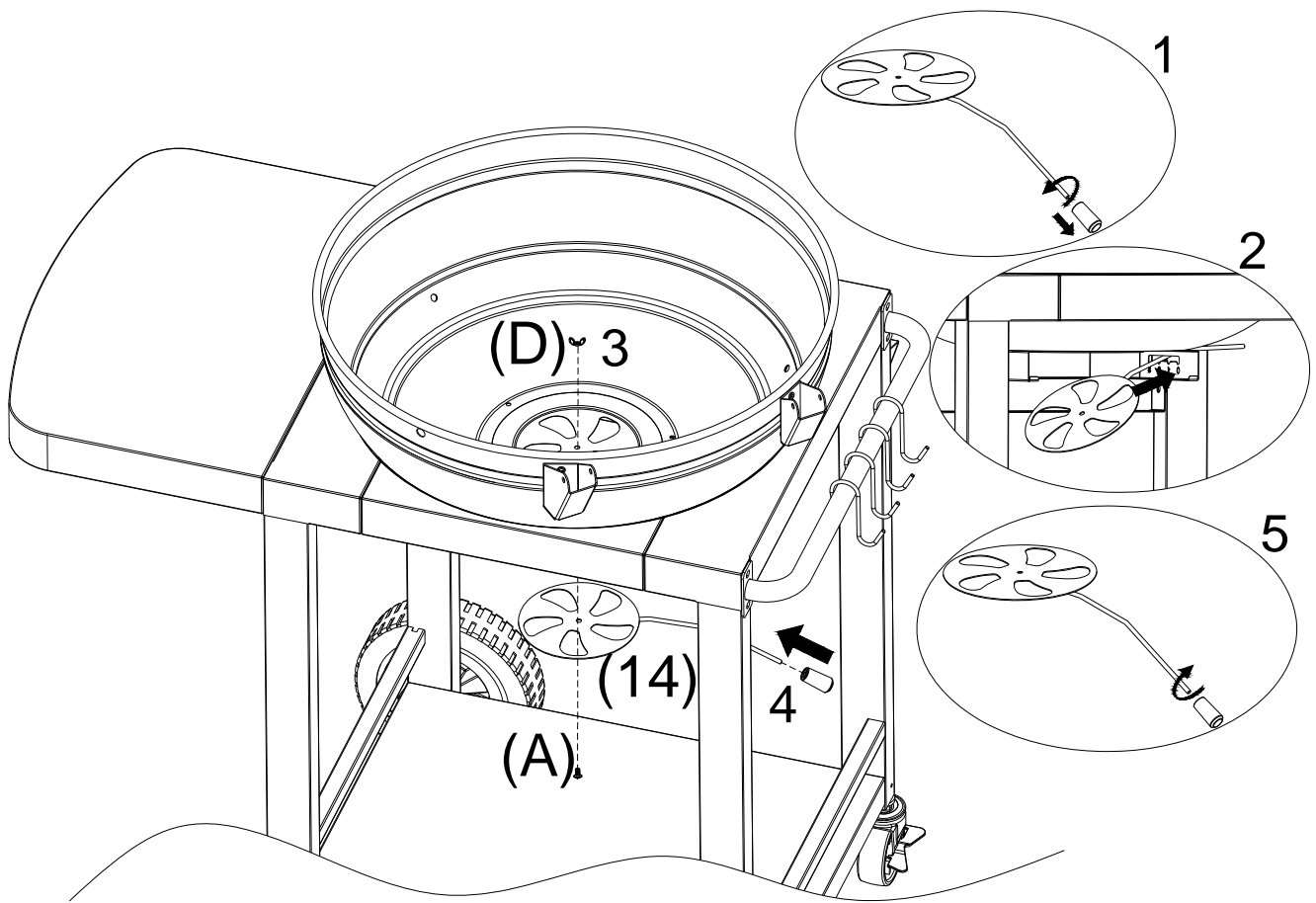

STEP 12:

A: Attach lid handle (3) to lid (4) ((H) Washer 2Pcs / (I) Lock Washer 2Pcs / (C) Screw 2Pcs).

B: Attach top hinge (7) to lid (4) ((C) Screw 4Pcs / (G) Washer 4Pcs / (I) Lock Washer 4Pcs / (E) Wing nut 4Pcs).

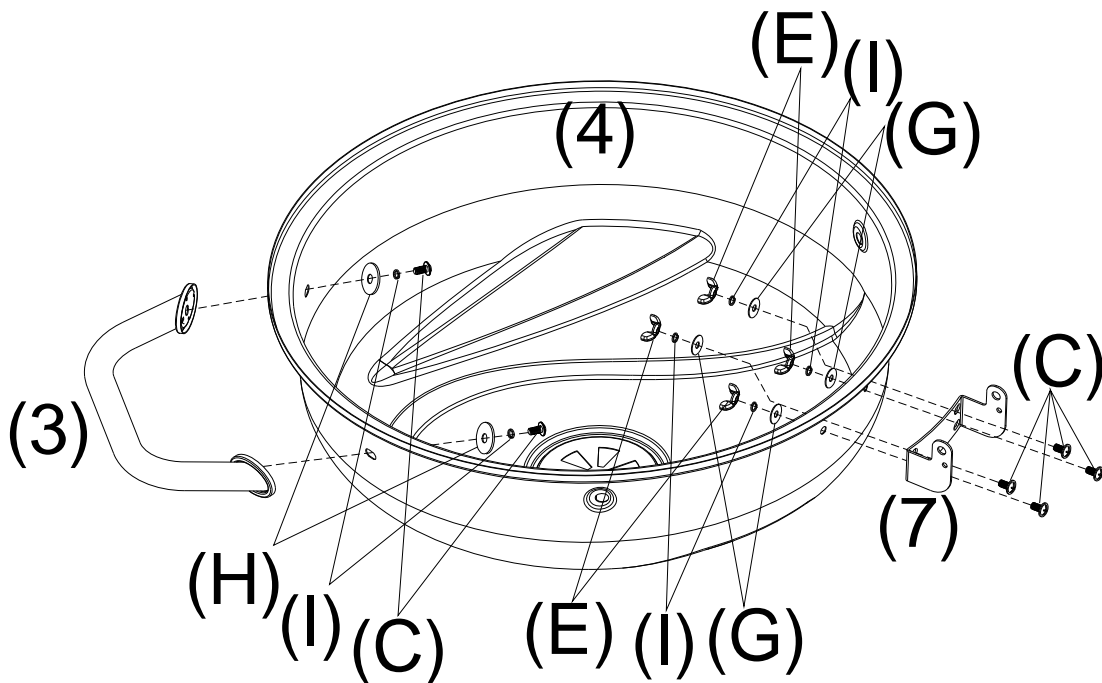

STEP 13:

A: Attach lid air vent (1) to lid ((A) Screw 1Pc / (D) Wing Nut 1Pc)

B: Attach temperature gauge (2) to lid.

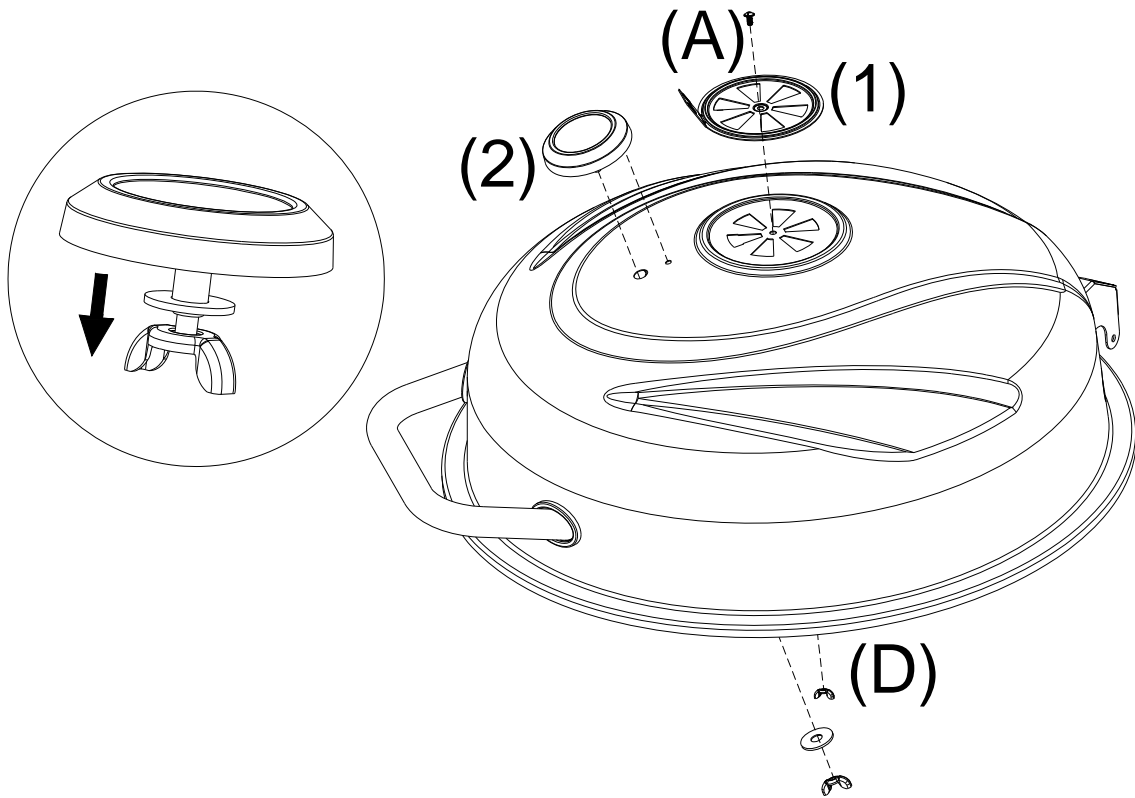

STEP 14:

A: Place the lid on firebowl.

B: Insert the Pin (J) into all these hinge holes.

C: Insert the Cotter Pin (K) at the end of Pin (J) ((J) Pin 2Pcs / (K) Cotter Pin 2Pcs).

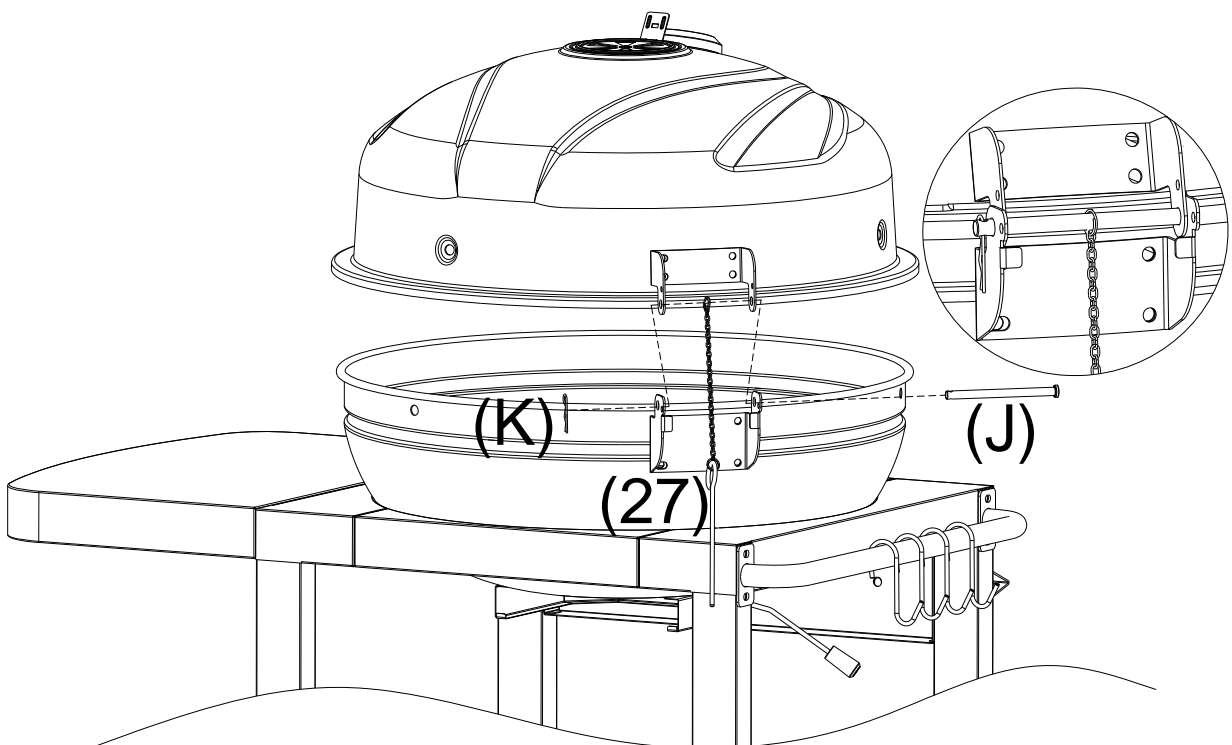

STEP 15:

A: Place the Charcoal grid (10) inside the firebowl.

B: Place the Cooking grid (6) on the firebowl.

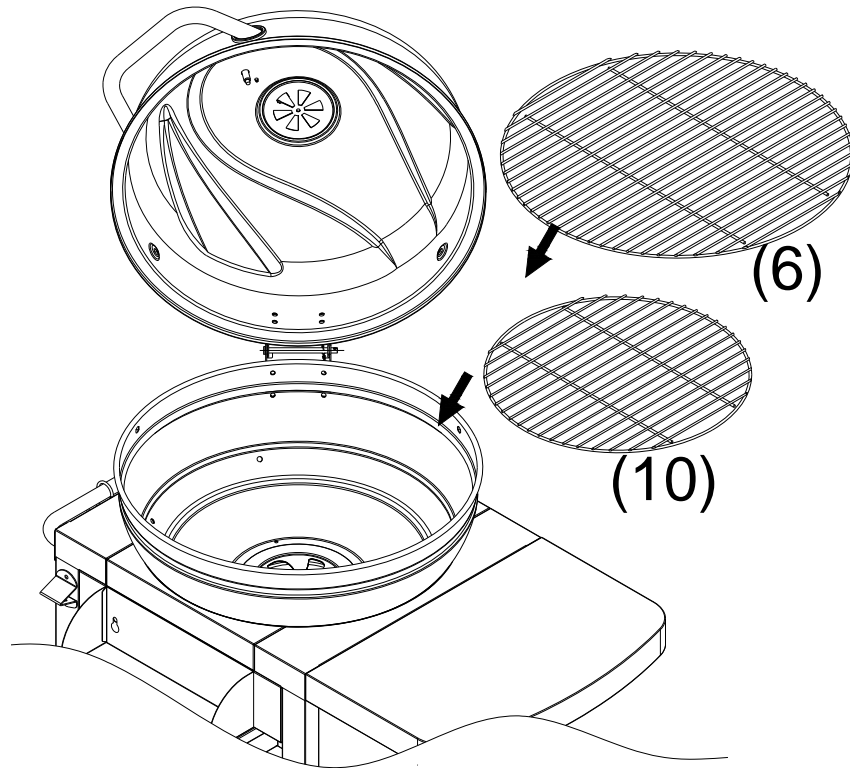

STEP 16:

A: Slide warming rack (5) into holes in lid and firebowl.

Note: Look for corresponding holes on side of lid, insert short wire end into lid hole one side at a time. Position warming rack legs into slots on firebowl sides.

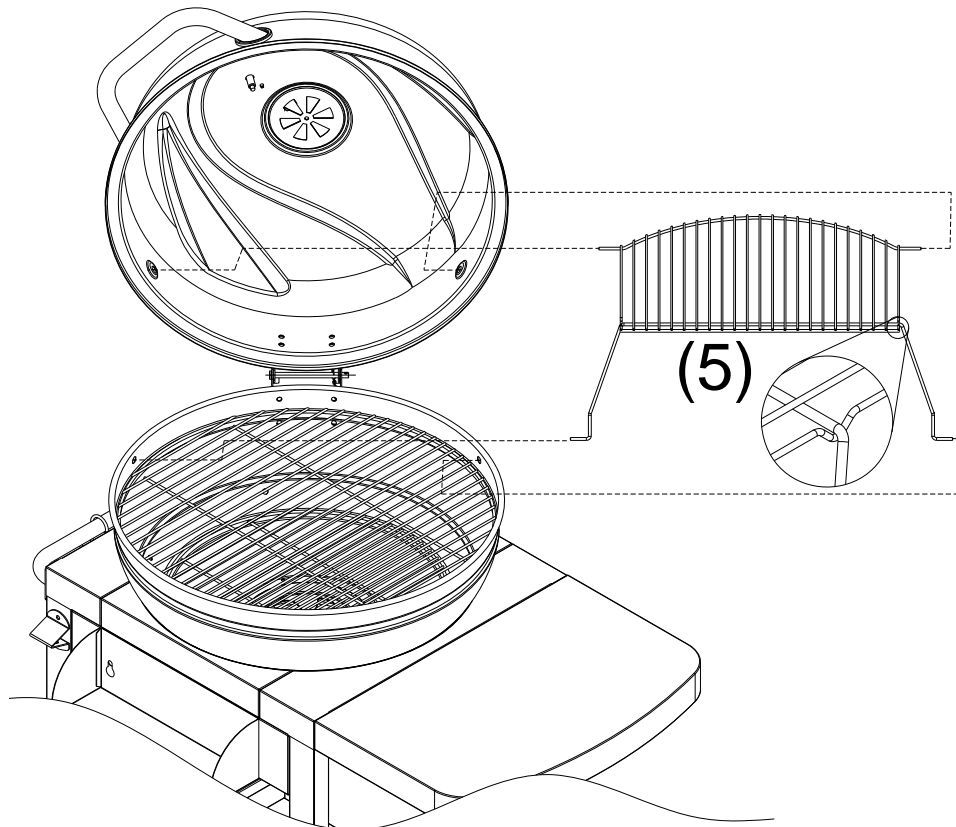

STEP 17:

A: Attach ash receiver (21) onto ash receiver support.

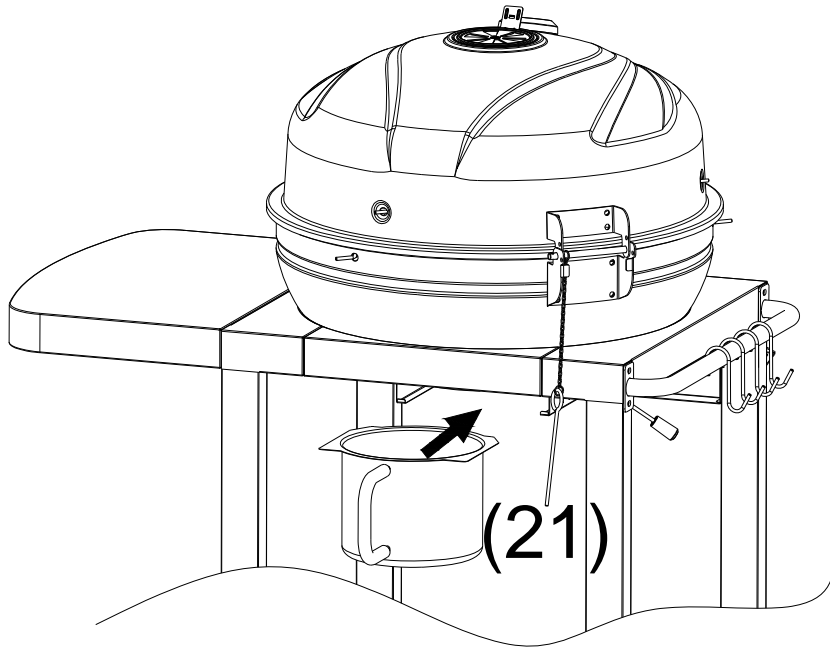

STEP 18:

WARNING! For your safety, always make sure the CHAIN PIN (27) must be inserted to secure the opened lid to prevent the lid fall back down accidentally or under strong wind.

A: Open the lid and make sure all holes at the back of upper & bottom hinges are lined up.

B: Insert the chain pin (27) into these holes to make the lid stand in a safe position.

C: Remove the chain pin (27) when you need to close the lid.

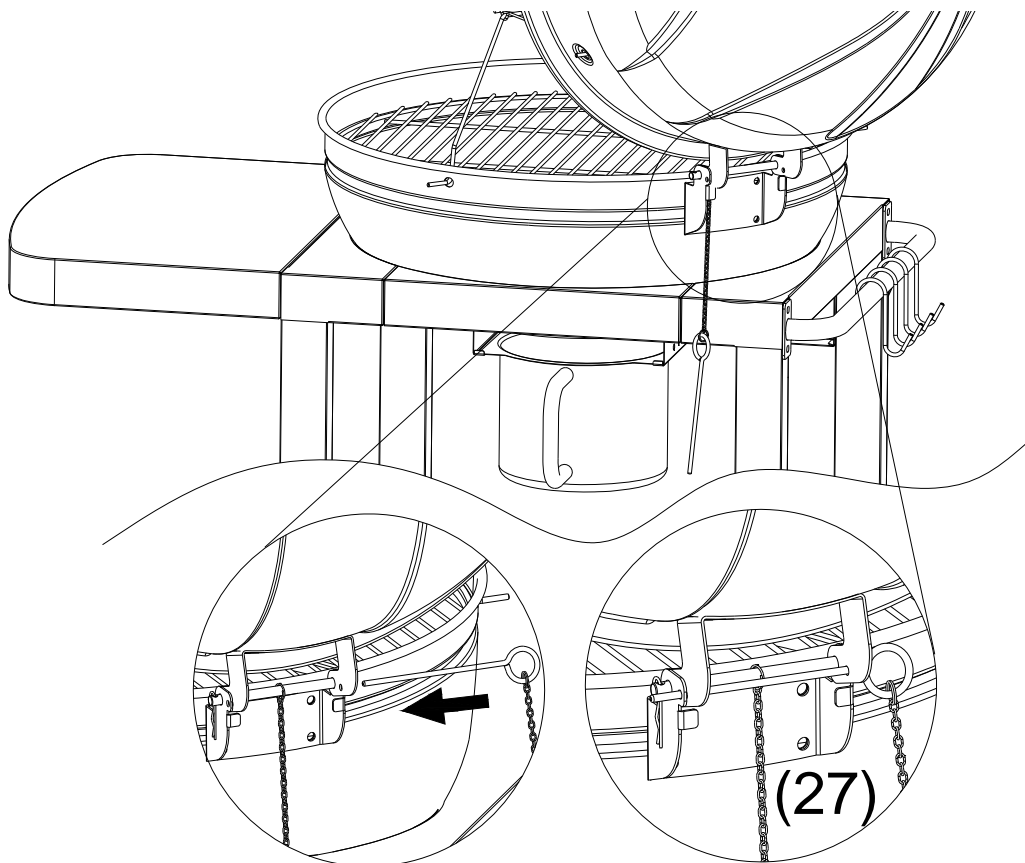

Instructions for use

Important: Read all the assembly instructions and safety warnings before use and keep these instructions in a safe place for future reference.

1. Make sure the assembly instructions have been followed correctly.
2. Set the barbecue up in a suitable position, on a level surface away from areas likely to catch fire.
3. Use charcoal and a suitable lighting method.
4. Please use cooking grid handle (28) to remove the cooking grid when adding charcoal into firebowl as below diagrams. Never touch the cooking grid by hand directly when the barbecue is hot or in use.

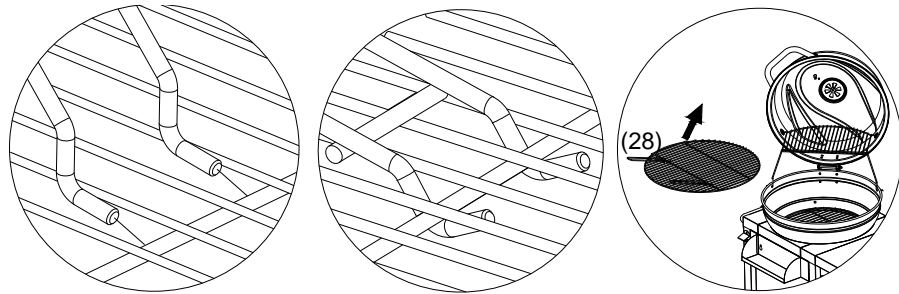

5. Do not touch the lid air vent by hand directly when the barbecue is hot or in use, use cooking grid handle (28) to adjust the air vent as below diagrams.

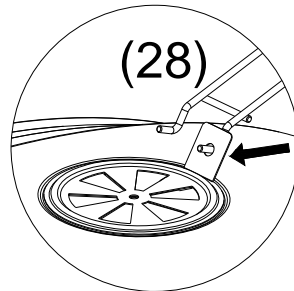

6. Do not touch the bottom air vent by hand directly when the barbecue is hot or in use, use bottom air vent handle to adjust the air vent as below diagrams.

Note: Adjust the firebowl air vent to open status.

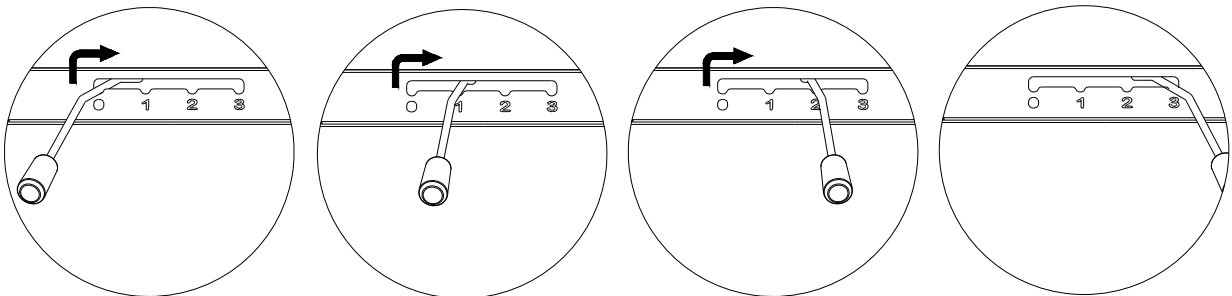

Note: Adjust the firebowl air vent to close status.

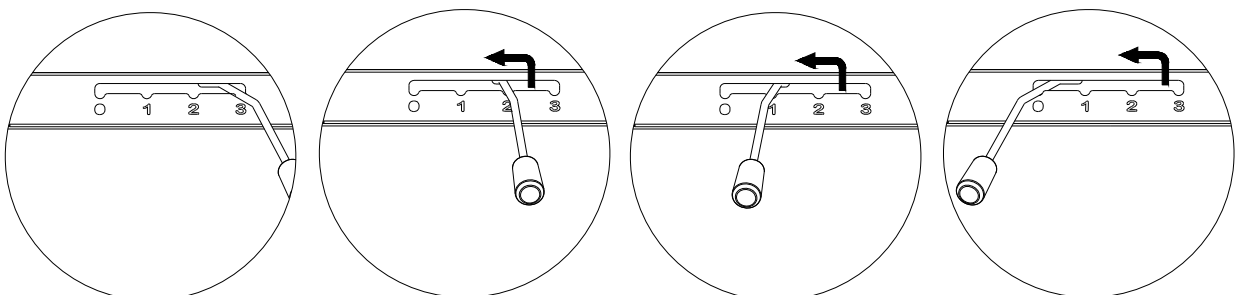

General Safety Warnings

Important: Read all the safety warnings and assembly instructions before use and retain all information for future reference.

1. **WARNING! BARBECUES SHOULD NEVER BE USED INDOORS. Only use the barbecue in the open air. Risk to life from fumes when used in an enclosed space.**
2. Never take a barbecue – or lit charcoal into an enclosed space, like a tent or caravan. Barbecues in enclosed spaces are lethal. The carbon monoxide from a badly adjusted barbecue can kill.
3. This barbecue will become very hot, do not move it during operation. Keep children and animals away. Keep away from flammable objects and materials.
4. Even though great care and attention has been taken to remove sharp edges, you should take care when handling components to avoid possible injury. The barbecue should be heated until the fuel is red hot at least 30 minutes before cooking.
5. Always stand your barbecue outdoors and on a level ground away from trees and wooden fencing.
6. **CAUTION! Do not use spirit or petrol for lighting or re-lighting. Use only firelighters complying with EN 1860-3.**
7. Do not light the fire with petrol, paraffin, methylated spirit, lighter fuel or alcohol.
8. Use specially formulated BBQ lighting fluid, paste or fire lighters.
9. Do not attempt to light the fire if lighting fluid has been spilt on clothing.
10. Do not try to re-light the fire with lighting fluid as the charcoal may still be hot and cause a flare up.
11. Never touch metal parts which may be hot.
12. During use always use protective gloves when touching any part of the barbecue.
13. Make sure the barbecue has completely cooled before removing the ash.
14. Keep a water sprayer handy to extinguish the flame.
15. Keep a fire extinguisher or fire blanket handy.
16. Never handle charcoal after lighting.
17. Never attempt to move the barbecue after the charcoal has been lit, as it will become very hot. Always wait until the barbecue has been completely cooled before attempting to move it.
18. Do NOT operate, light or use this appliance within ten feet (3.05m) of walls, structures or buildings.
19. Minimum clearance from sides and back of unit to combustible constructions is 91.4 cm.
20. Prevent CO poisoning. Make sure exhaust from generators is properly vented away from occupied areas. Carbon Monoxide (CO) is a colourless, odourless, highly poisonous gas that can kill in minutes. Carbon Monoxide poisoning can be caused by ANY fuel that burns or smoulders. Watch out for the symptoms – Mild headache / Dizziness / Nausea Vomiting / Fatigue / Drowsiness.
21. **WARNING! MAXIMUM CHARCOAL WEIGHT to be used: TOTAL 1.6 kg.**

	<p>CARBON MONOXIDE HAZARD</p> <p>Burning charcoal inside can kill you. It gives off carbon monoxide, which has no odour.</p> <p>NEVER burn charcoal in enclosed spaces e.g. homes, vehicles or tents</p>
---	--



22. Do not use the barbecue in a confined and/or habitable space e.g. houses, tent, caravans, motor homes, boats. Danger of carbon monoxide poisoning fatality.

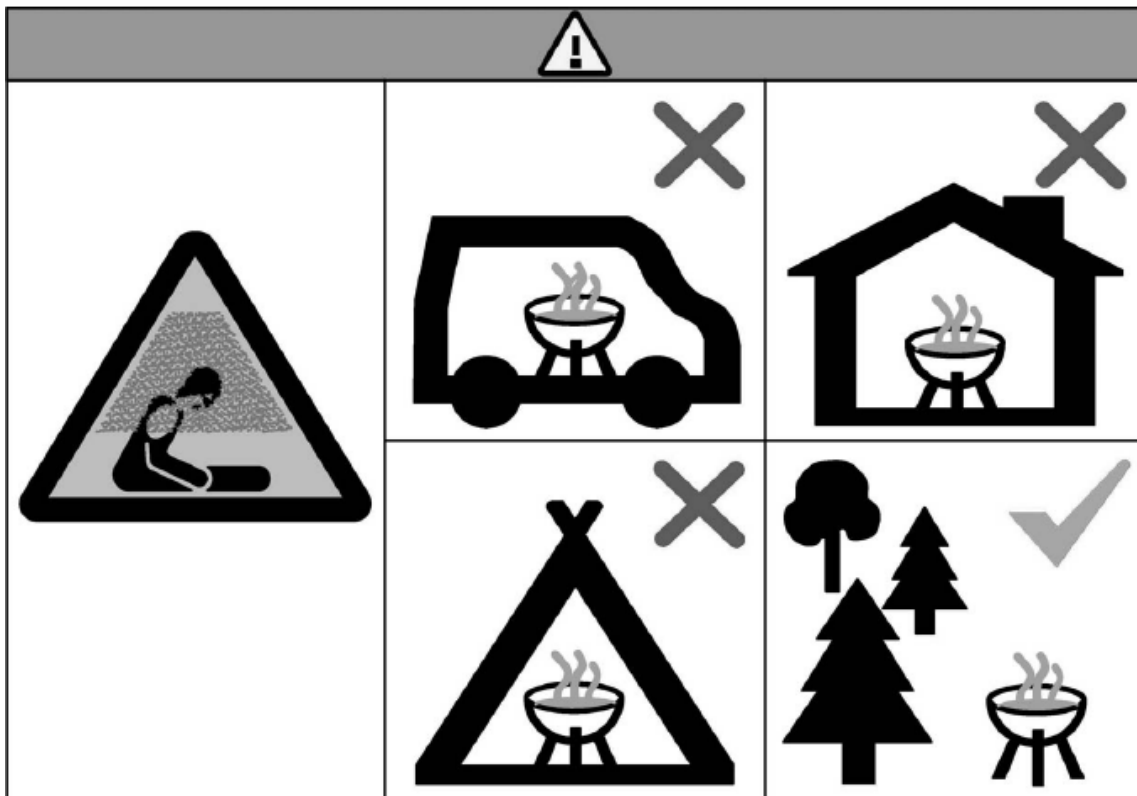

Barbecue safety hints

1. Outdoor use only.
2. Always stand your barbecue on firm, level and heat-resist surface, well away from wooden fences, overhanging trees and other flammable materials.
3. The barbecue must always be under the control of a competent adult. Keep young children and pets at a safe distance once the charcoal has ignited.
4. Never use white spirit, paraffin, petrol, methylated spirit, lighter fuel or similar solvents to light the barbecue. To help ignition, only use firelighters that comply with EN 1860-3. Never add lighting fuel, once the charcoal has ignited.
5. Never attempt to move the barbecue after the charcoal has been lit, as it will become very hot. Always wait until the barbecue has completely cooled before attempting to move it.
6. Do not leave a lighted barbecue unattended, even for the shortest period of time.
7. The barbecue should be heated up and the fuel kept red hot for at least 30 minutes prior to the first cooking on the barbecue.
8. **Do not cook before the fuel has a coating of ash.**
9. Most metal parts will become very hot during use. The use of protective mittens/gloves is recommended when handling the grill, turning food, etc.
10. Flare-ups will occur when the hot fat from food drips onto the charcoal. Keep a jet water sprayer at hand to extinguish any flames and prevent food from burning.
11. When cooking has finished, extinguish the charcoal using a fine water spray or by covering with sand.
12. Remember, ensure the charcoal has completely cooled before attempting to empty the barbecue and clean it.
13. To prolong the life of the metal parts, do not leave the barbecue outside and unprotected from the weather. Ideally it should be stored in a garage or garden shed when not in use.
14. If the product is broken or damaged discontinue use immediately.

Barbecue helpful hints

1. To make it easier to clean your barbecue after use line the firebowl with aluminum cooking foil, shine side up. Remember to leave ventilation holes clear by piercing the foil where necessary.
2. Charcoal is available in lump wood form (large irregular pieces) and as briquets (uniformly sized pieces). As a guide lump-wood charcoal is best in barbecue for quickly cooked foods such as sausages and burgers whilst briquets are more suitable for a roast as they burn longer and hotter.
3. It is not advisable to completely fill the firebowl as the barbecue may become far too hot to cook successfully.
4. If the fire flares up due to dripping fat then douse the flames lightly with a fine water spray.
5. When you have finished cooking never pour cold water directly on the coals to extinguish them as this may damage your barbecue. Use old cinders, sand or a fine water spray.
6. To clean your barbecue soak the cooking grill and tools in hot soapy water as soon as possible after use. Dry thoroughly and store in a dry place. Do not leave your barbecue outside unprotected.



Now for the serious stuff.
Proof of purchase required.
All of this is in addition to your
statutory rights.

**Produced in China for Wilko, Roebuck Way,
Manton Wood, Worksop, Nottinghamshire, S80 3EG
Careline 08000 329 329 www.wilko.com**