

Outdoor Portable Charcoal Grill

Model No. P1809MIA

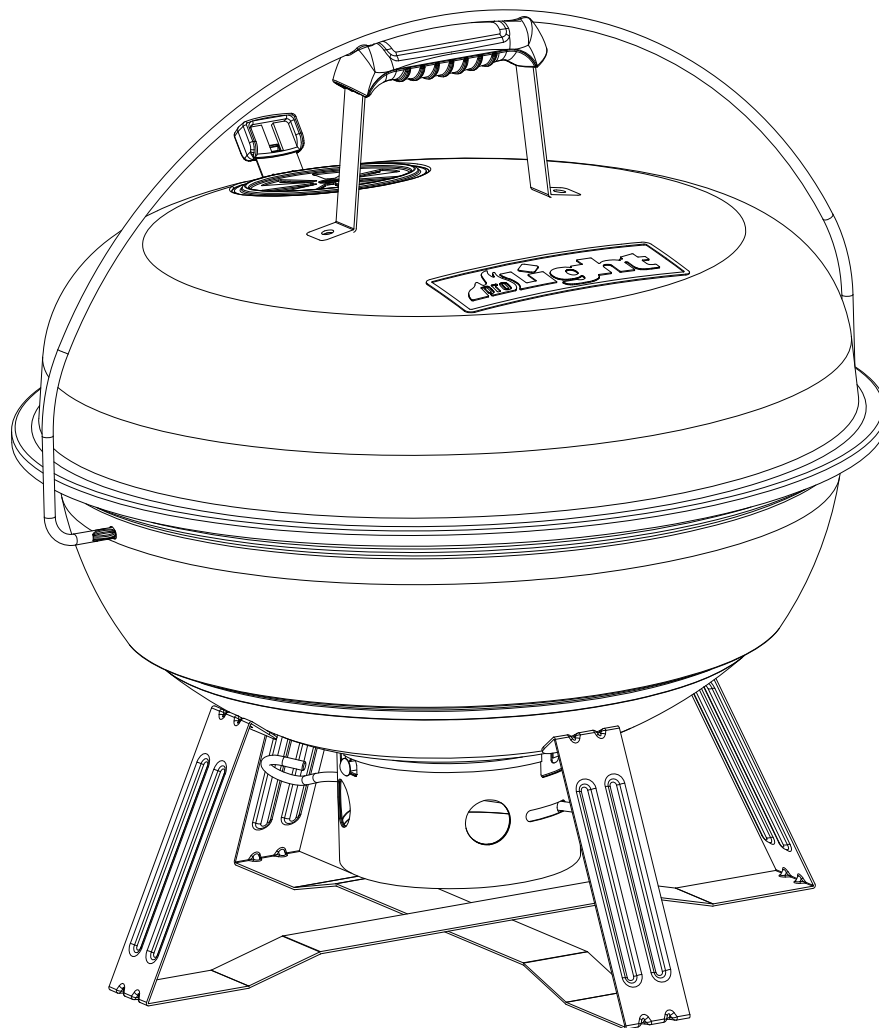

For Outdoor Use Only!

Warning! Be careful of sharp edges during assembly.

Made In China

Save these instructions for future reference. If assembling this unit for someone else, give them this manual to read and save for future use.

Parts & Hardware List

Parts List	Expanded View
1. Air vent 2. Lid handle 3. Lid 4. Cooking grid 5. Charcoal grid 6. Bottom bowl 7. Wire handle 8. Ash receiver 9. Leg (2)	
Hardware List (Included)	
A: Screw M4x5 Nickel Plated Single Phillips Truss Head 3Pcs /	
B: Screw M4x10 430SS Truss Head 1Pc /	
C: Screw M5x12 Nickel Plated Phillips Truss Head 6Pcs /	
D: Round nut M4 Nickel Plated 3Pcs /	
E: Wing nut M4 Nickel Plated 1Pc /	
F: Wing nut M5 Nickel Plated 6Pcs /	
G: Washer \varnothing 5 Nickel Plated 6Pcs /	
H: Washer \varnothing 6 Nickel Plated 2Pcs /	
I: Washer \varnothing 6 Heat Resistant 2Pcs /	
J: Lock washer \varnothing 5 Nickel Plated 6Pcs /	
Tools Required for Assembly (Not Included)	
Screwdriver /	

Assembly Instructions

For easiest assembly:

1. Choose an area with a smooth surface, free of cracks and openings that will protect components during the assembly process.
2. Spread out all parts.
3. Tighten all hardware connections by hand first. Then, before completing each step, go back and fully tighten all hardware. Be careful not to over-tighten. That could damage surfaces or strip threads.
4. For best results, complete each step in the order presented.

Typical assembly is approximately 25 minutes.

Step 1

Attach lid handle to lid (C Screw 2Pcs / I Washer 2Pcs / G Washer 2Pcs / J Lock washer 2Pcs / F Wing nut 2Pcs).

Attach air vent to lid (B Screw 1Pc / E Wing nut 1Pc).

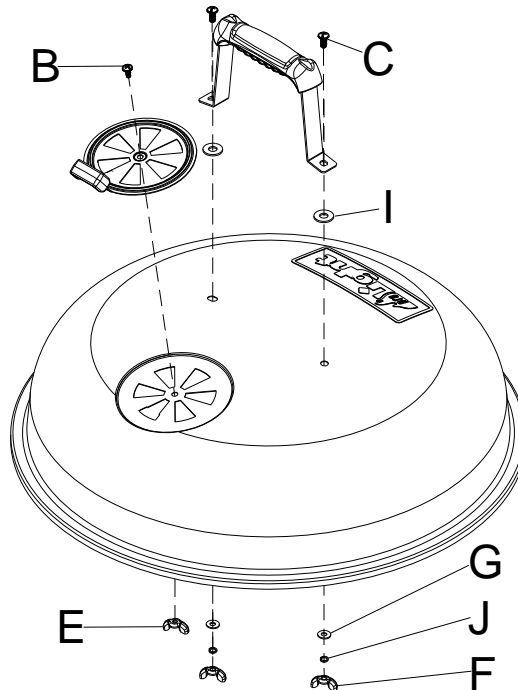

Step 2

Attach screw A and round nut D to bottom bowl (A Screw 3Pcs / D Round nut 3Pcs).

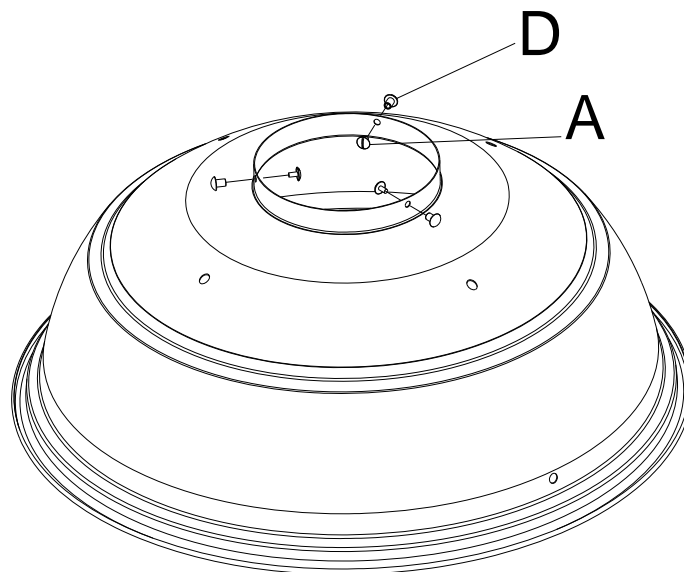

Step 3

Attach leg to bottom bowl (C Screw 4Pcs / G Washer 4Pcs / J Lock washer 4Pcs / F Wing nut 4Pcs).

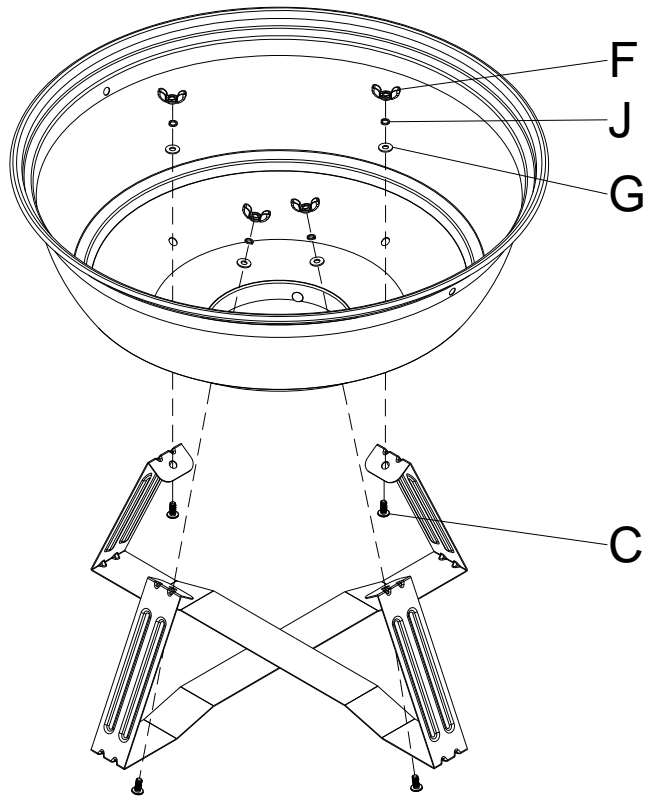

Step 4

Attach ash receiver to bottom bowl.

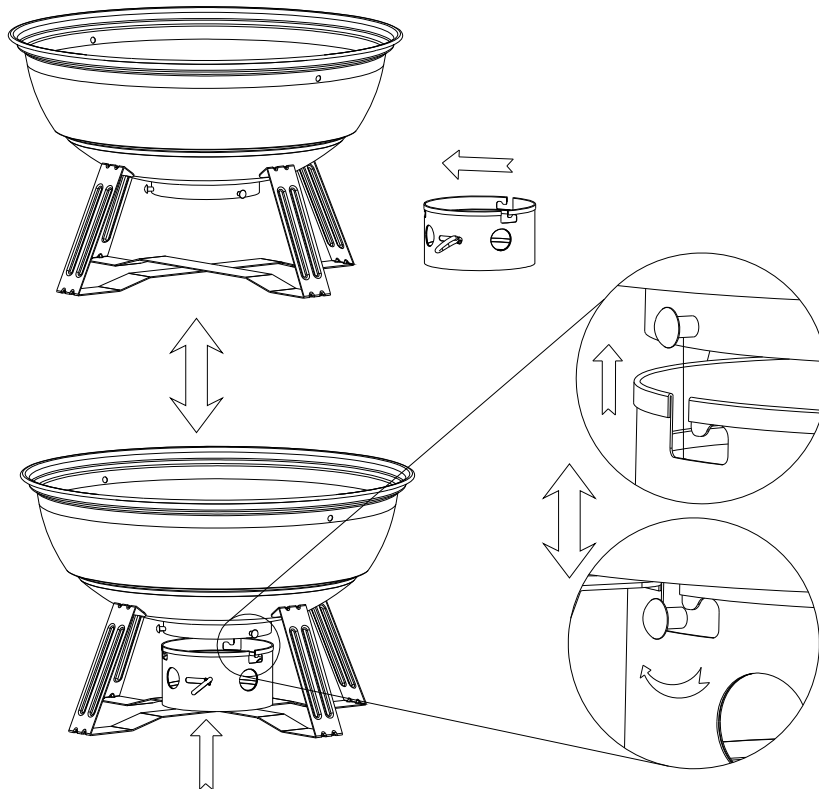

Step 5

Attach wire handle (H Washer 2Pcs).

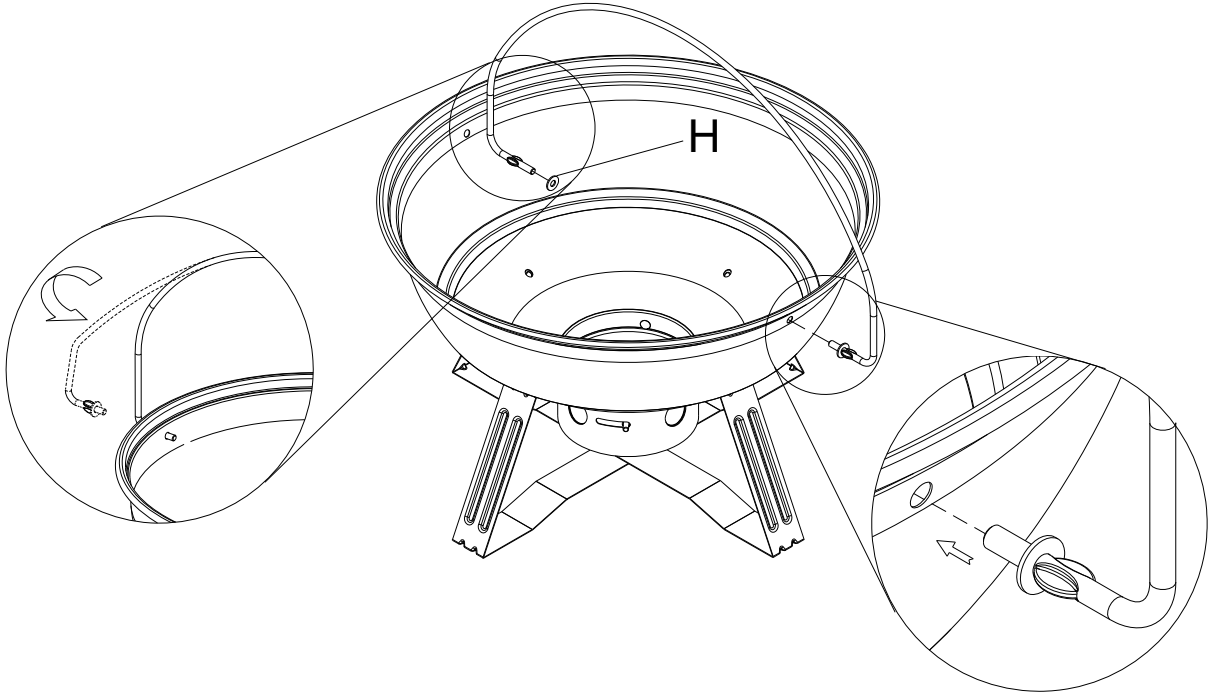

Step 6

Insert charcoal grid into bottom bowl.
Insert cooking grid into bottom bowl.
Cover lid onto bottom bowl.

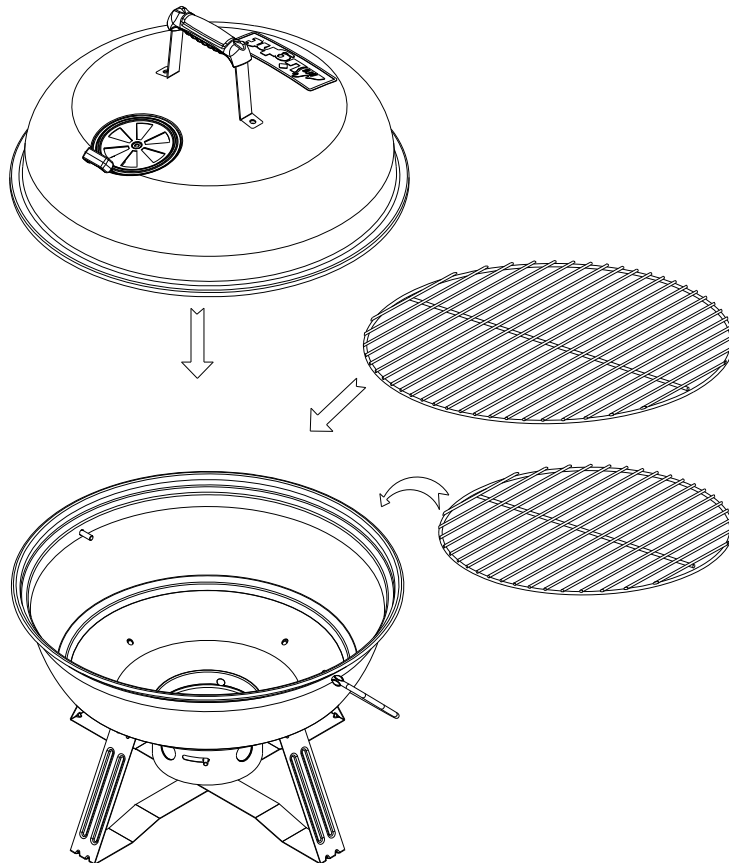

Step 7

Congratulations, your assembly is now complete. Read operating instructions before proceeding.

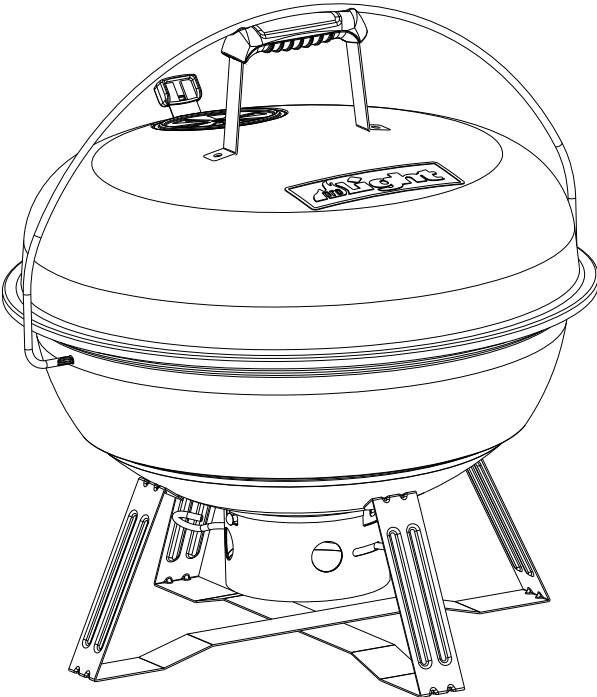

SAFETY HINTS

1. Stand your grill on a safe, level surface away from flammable items such as wooden fences, house siding, overhead lines or over hanging tree branches. NEVER USE your grill indoors.
2. DO NOT use petrol, paraffin, methylated spirit or lighter fuel to light your charcoal.
3. Once lit, DO NOT move your grill or leave it unattended.
4. Keep children and pets a safe distance from the grill.
5. Keep a fire extinguisher handy.
6. Remember that hot fat may drip out of the bottom bowl so keep your feet clear.
7. DO NOT touch metal parts of grill until it has completely cooled to avoid burns. All handles will be hot and must be handled with care and caution. Use protective gear, such as pot holders or BBQ gloves, when handling the grill.
8. Ensure that the coals have completely cooled before removing the ash.

HELPFUL HINTS

1. To extend the life of your grill and help reflect the heat more efficiently, line the bottom bowl with aluminum foil. Leave ventilation holes clear by piercing the foil where necessary.
2. Charcoal is available in lump form (large irregular pieces) and briquettes (uniformly sized pieces). Lump charcoal is best in grills for quick-cook foods such as sausage and burgers while briquettes are more suitable for slow-cooked meats.
3. To start your fire, put a small quantity of charcoal in a pyramid shape. Douse the charcoal evenly with lighter fluid and allow to soak a couple minutes. Light the charcoal with flame and allow them to burn until they are covered with ash. Spread the coals evenly over the bottom bowl. Do not completely fill the fire bowl with charcoal as the grill may become too hot to cook successfully.
4. If the barbecue is cooking too quickly, either raise the cooking grid or spread the coals further apart using long handled tongs. If you need to replenish the charcoal, always add to the sides and not to the center of the fire.
5. If the fire flares up due to dripping fat, reduce the flames with a fine water spray.
6. When you have finished cooking, never pour cold water directly on the coals to extinguish them as this may damage your grill. Use old cinders, sand, or a fine water spray.
7. To clean your grill, soak the cooking grate and tools in hot soapy water as soon as possible after use. Dry thoroughly and store in a dry place. Do not leave your grill outside unprotected.

DANGER!

DO NOT use charcoal briquettes for indoor cooking or heating. TOXIC carbon monoxide fumes can accumulate and cause asphyxiation. Live hot briquettes can create a fire hazard.

DANGER!

It is not intended to be installed in or on recreational vehicles and/or boats.